



**EULE INDUSTRIAL
ROBOTICS**

the automation company

ToolConnector TS2

User-Manual Part I Hardware

Version 1.0.3



1. Content

1. Content.....	1
2. Version history	3
3. Function and intended Use	3
4. Performance and Setup	4
5. Type-Key.....	6
6. Mechanics	7
6.1. Attaching to the Robot (without bellows).....	7
6.1.1. Installation	8
6.1.2. Removing.....	8
6.2. Attaching to the Robot (with bellows)	8
6.2.1. Installation	10
6.2.2. Removing.....	10
6.3. User-sided Assembling	10
6.3.1. Flange ISO 9409-1-40-4-M6.....	10
6.4. Case Options.....	11
6.4.1. Case with Screw Joints.....	11
6.4.2. Case with Grommets	11
6.4.3. ESD Option	11
6.4.4. FDA Option	11
7. Electrical System	12
7.1. Power-Supply Unit (19-1011-100-01).....	12
7.1.1. Block Diagram	12
7.1.2. Voltage Supply (X200).....	13
7.1.3. Fuses	13
7.1.4. Diagnostic Indicator Lights (LED)	13
7.1.5. Supply Plug (X20x, X21x).....	14
7.1.6. Device-Bus (X100).....	14
7.2. Mainboard EtherCAT (19-1011-101-01 Ver. 1.2)	15
7.2.1. Device-Bus (X100).....	15
7.2.2. EtherCAT in/out	15
7.2.3. IOLink.....	15
7.2.4. Voltage Supply IO-Link (X211)	16
7.2.5. Voltage Selection IO-Link (J1)	16
7.2.6. LED-Bus (X8, X9).....	16
7.2.7. Service-Port (X4)	16
7.2.8. IR-Interface (IR).....	16
7.2.9. Pushbutton (SW1).....	16
7.2.10. Diagnostic Indicator Lights (LED)	17
7.2.11. Remote Control	17
7.3. Digital Inputs DI16 (19-1011-102-01 Ver. 1.1).....	18
7.3.1. Technical Data	18
7.3.2. Block Diagram.....	18
7.3.3. Device-Bus (X100).....	18
7.3.1. Voltage Supply (X201).....	19
7.3.2. Input Terminal	19
7.3.3. Diagnostic Indicator-Lights (LED).....	19

7.4. Digital Outputs DO16 (19-1011-103-01 Ver. 1.1)	20
7.4.1. Technical Data	20
7.4.1. Block Diagram	20
7.4.2. Device-Bus (X100)	20
7.4.3. Voltage Supply (X212)	21
7.4.4. Output Terminal	21
7.4.5. Diagnostic Indicator Lights (LED)	21
7.5. Case LEDs	22
8. Pneumatic System	23
8.1. Valve Blocks	24
8.1.1. Types of Valve Blocks	24
8.1.2. Valve Block Installation/Removing	24
8.2. Valves	25
8.2.1. Types of Valves	25
8.2.2. Valves Installation/Removing	26
9. Spare Parts	27

2. Version history

Version	Modification	Date
1.0.0	Initial Version	05.11.2020
1.0.1	1 st Revision	12.01.2021
1.0.2	Extended Version with Bellows, Extending of 2 nd Valve Block, Correction/Addition of Spare Parts	05.07.2022
1.0.3	IR RC2 added	02.12.2022

3. Function and intended Use

The *ToolConnector* is intended for operations on a class TS2 Stäubli Robot. The installation, the connecting and the operation of the device have to happen according to this manual.

This component delivers no safety functions in terms of human- or machine-safety. Functional safety needs to be ensured by superior systems.



Every using beyond the terms of this manual, is seen as not intended use.

Electrical and mechanical works are allowed to be done by qualified personal only.

4. Performance and Setup

The *ToolConnector* is produced to be an universal interface for connecting tools to the TS2 Scara-Robot. Therefore it provides both mechanical and electrical and also pneumatic interfaces.

Due to its modular setup the *ToolConnector* is configurable individually.

The installation at the robot occurs directly to the robots ballscrew by a collet. It is no robot-sided flange necessary.

A normal-flange (s. Type-Key) is available on the bottom side to connect a picking-tool mechanically.

The free cross section throughout the ballscrew is $\varnothing 18\text{mm}$. Outlets on the side are available to reach the inside of the *ToolConnector*.

On the electrical side there are different combinations of bus-interfaces as well as in- and output-modules available (see Type-Key).

On the pneumatic side it is possible to install up to four (seven)* valves with various functions (see Type-Key). It is also possible to assemble two (four)* different pressure-circles. (* with 2nd valve block)

Several variations of the case are available with screw-joints, cable-grommets as well as compatible to ESD- or food-purposes.

The *ToolConnector* is equipped with two diagnostic displays.

The mass of the complete system depends on the setting and lies between 900gr and 1400gr.

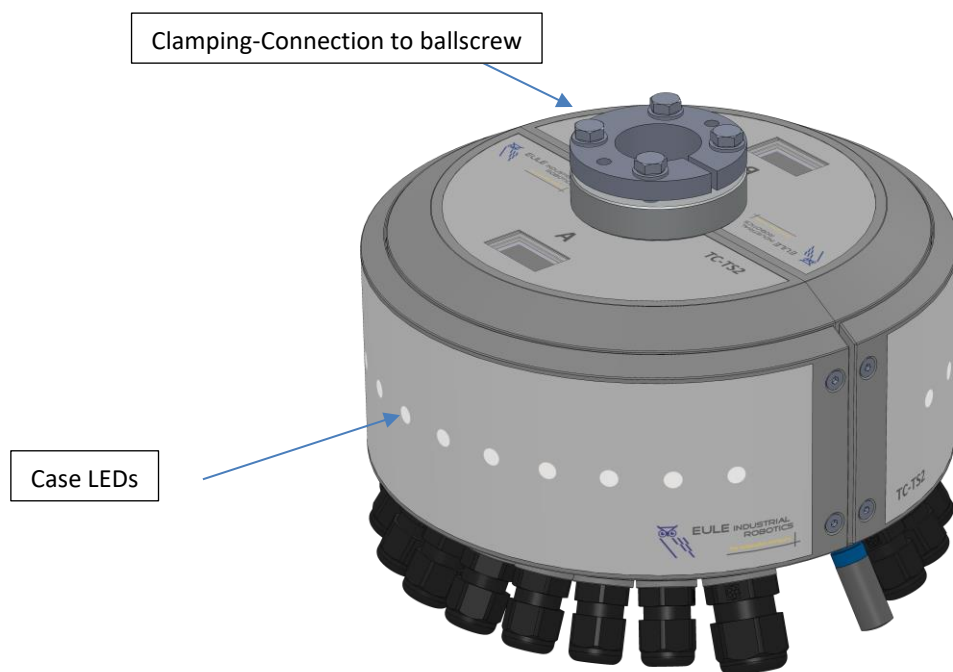

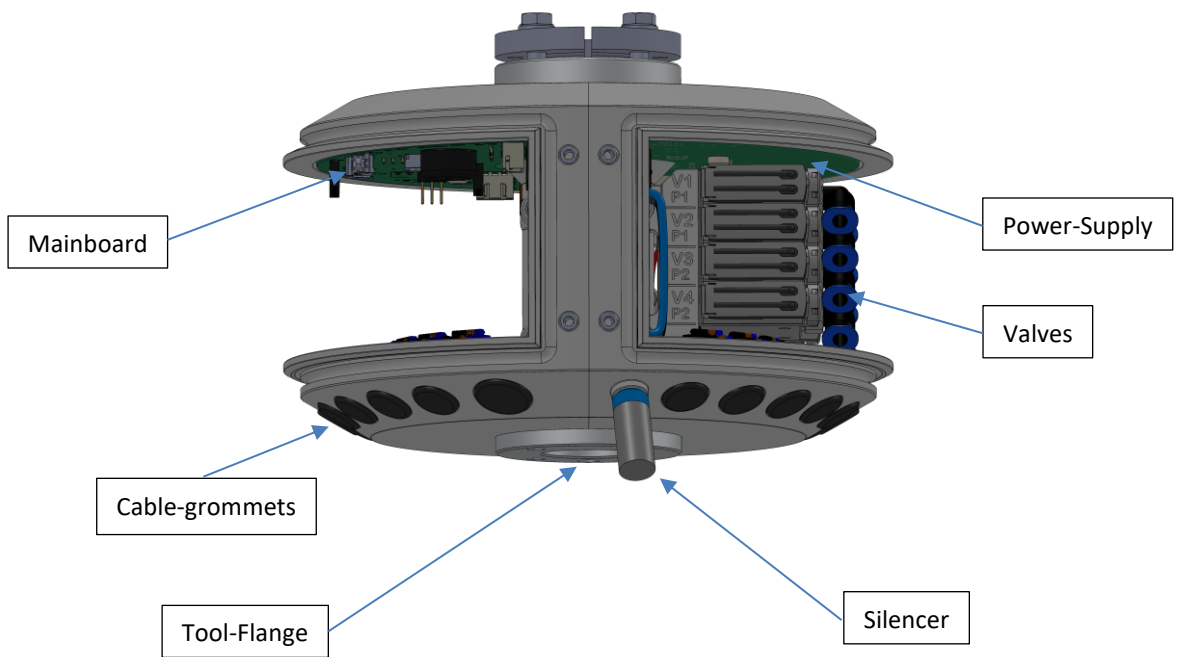
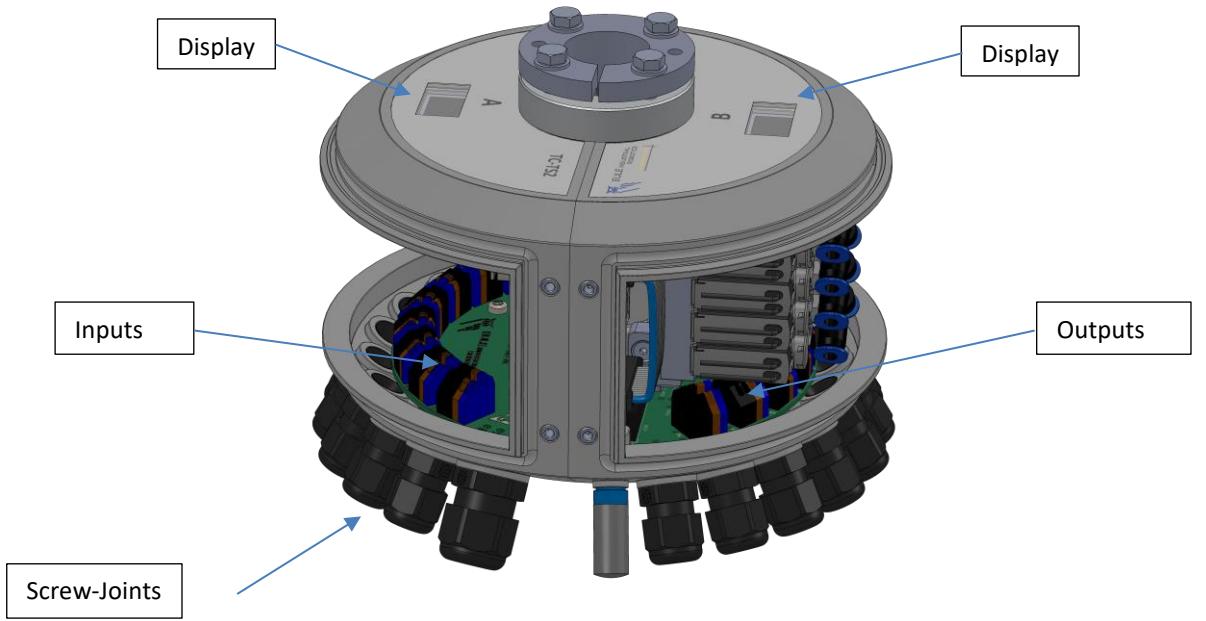

5. Type-Key

The type-key of the device is explained in the following:

TC-TS2-aaa-bb-cc-dd-ee-ff-g-hh-ijjj [-iXjjj]*

Key	Code	Function	
Product-Key	TC-TS2	<i>Tool/Connector</i> for Stäubli TS2	Chapter 6 – Mechanics
System-Height (aaa)	080	System-Height 80mm	
	081	System-Height 134mm (80mm + 54mm) for bellows installation	
Flange (bb)	04	ISO 9409-1-40-4-M6	
Case (cc)	01	Standard (grey) with screw-joints	
	02	Standard (grey) with grommets	
	11	ESD (grey) with screw-joints	
	12	ESD (grey) with grommets	
	21	FDA (white) with screw-joints	
Bus-Interface (dd)	EC	EtherCAT	Chapter 7 – Electrics
Input Module (ee)	00	Without	
	01	16 digital Inputs	
Output Module (ff)	00	Without	
	01	16 digital Outputs	
LED-Band (g)	0	Without	
	1	24 RGB-LEDs	
Gateway (hh)	00	Without	
	01	IO-Link 1-Channel Master	
Valve Block (i)	0	Without	Chapter 8 – Pneumatics
	1	P-Pressure-Circuit 1/3	
	2	P-Pressure-Circuit 2/2	
Valves (j) 4x	X	Dummy Board	
	A	5/2-Way Valve, monostable	
	B	5/2-Way Valve, bistable	
	C	5/3-Way Valve, Center Position closed	
	D	5/3-Way Valve, Center Position vented	
	E	5/3-Way Valve, Center Position ventilated	
	F	2x 3/2-Way Valve, Rest Position closed	
	G	2x 3/2-Way Valve, Rest Position open	
H	2x 3/2-Way Valve, Rest Position open/closed		

* 2nd Valve Block

For the 2nd valve block there is added an additional -iXjjj group to the ordering code. The 1st valve position is not available (X). So it is possible to install a maximum of 7 valves.

This option is not available in combination with the Gateway IO-Link Master option.

6. Mechanics

6.1. Attaching to the Robot (without bellows)

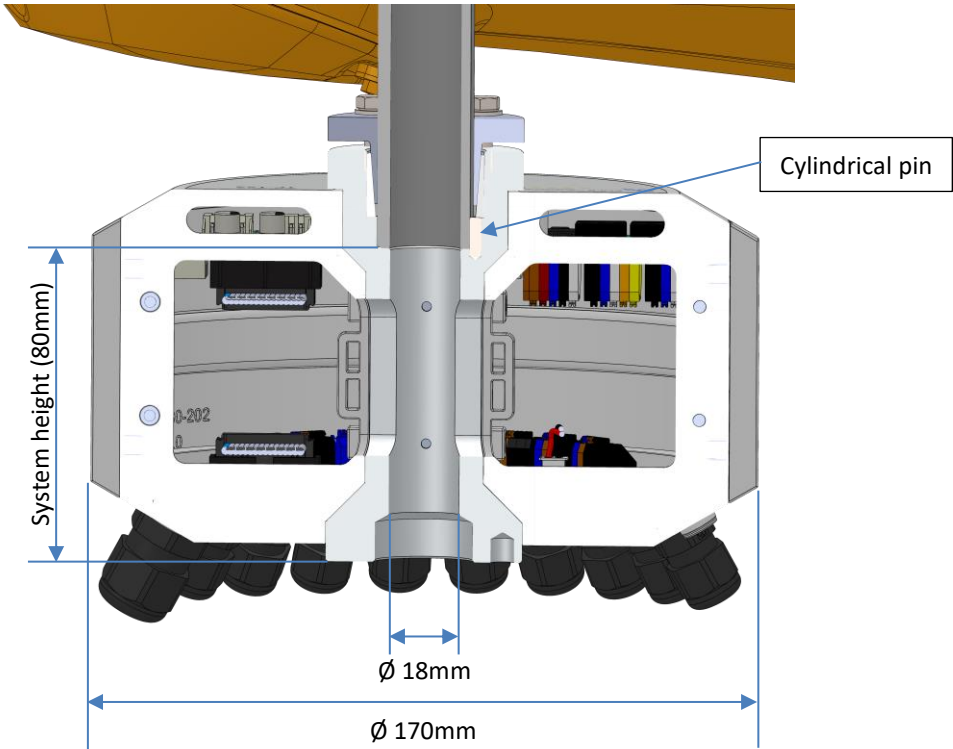
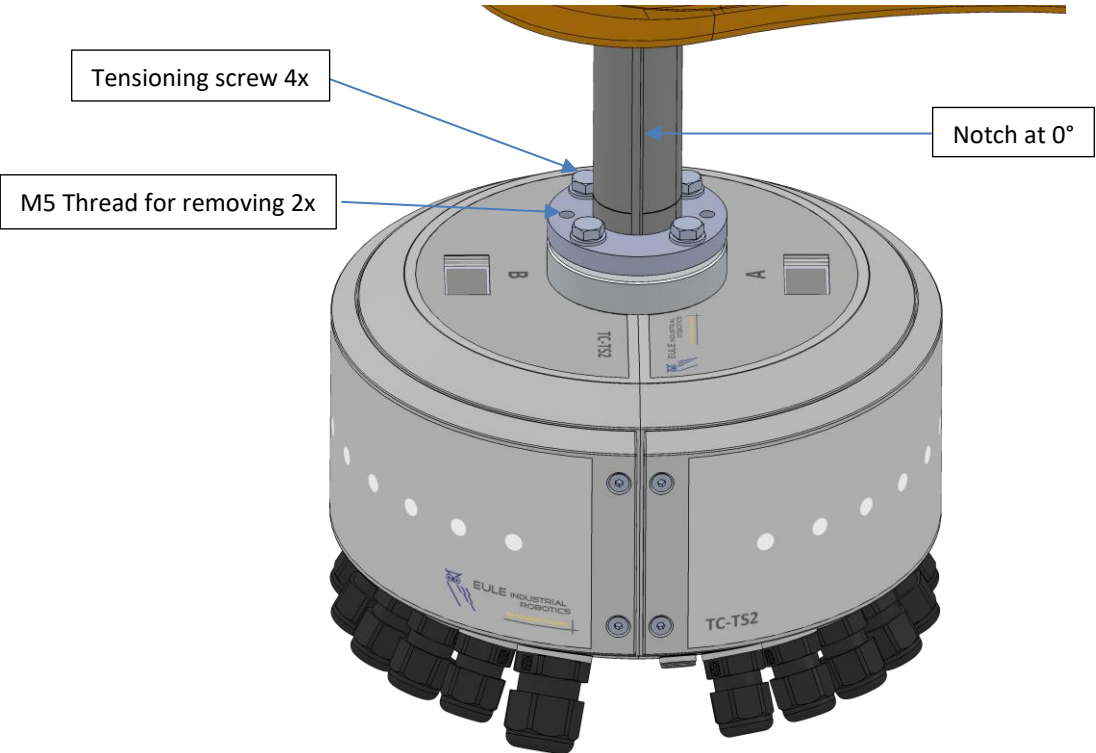

6.1.1. Installation

Make sure the ballscrew is extended so far, that enough workspace is located between the robot's case and the *ToolConnector* and that the position of the guide notch at 0 degrees is well known. There are 3 guide notches with 120° between each other. The notch at 0° can be identified clearly by the display on the manual control panel only. Loosen the 4 tensioning screws by about 5 rotations. Pull the collet out of the socket until the ballscrew is easy to insert. Now push the ballscrew into the guidance until the limit stop. Consider that the cylindrical pin fits to the ballscrew's guide notch at 0°. Then the pinhole at the flange is also at 0°. Tighten the 4 tensioning screws uniformly in several runs (tightening moment 5 NM). Precede diagonal here. The use of a screw locking (e.g. LOCTITE 222) is highly recommended.

6.1.2. Removing

Make sure the ballscrew is extended so far, that enough workspace is located between the robot's case and the *ToolConnector*. Disconnect all connections that are running up the ballscrew. **Secure the *ToolConnector* from falling down.** Loosen the 4 tensioning screws by about 5 rotations. Now screw the two M5 x 15 (or longer) screws into the both assistance-threads until they have a freewheeling touch to the limit stop. Turn each of these two screws alternately forward until the *Toolconnector* can be detached easily from the ballscrew.

6.2. Attaching to the Robot (with bellows)

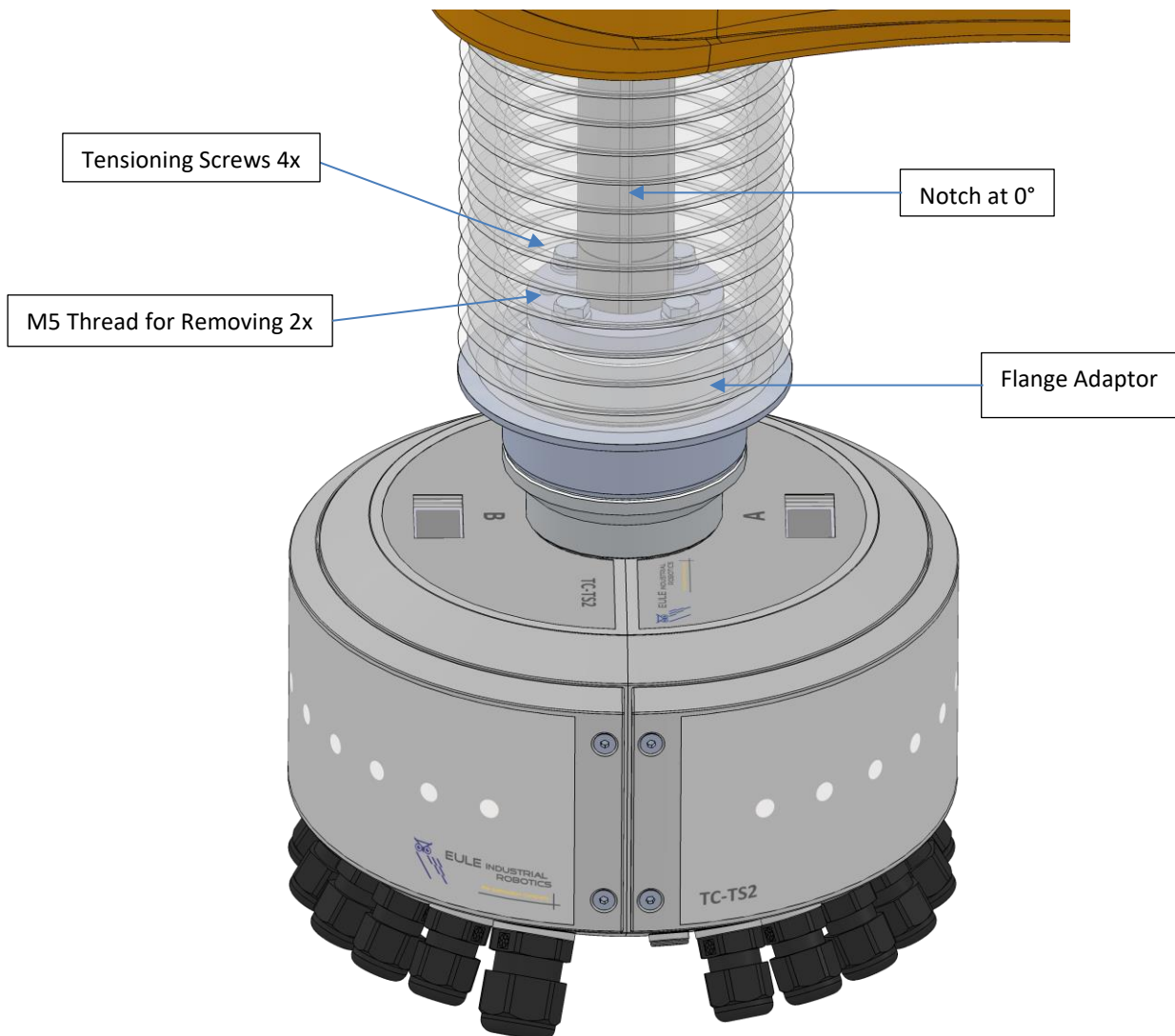

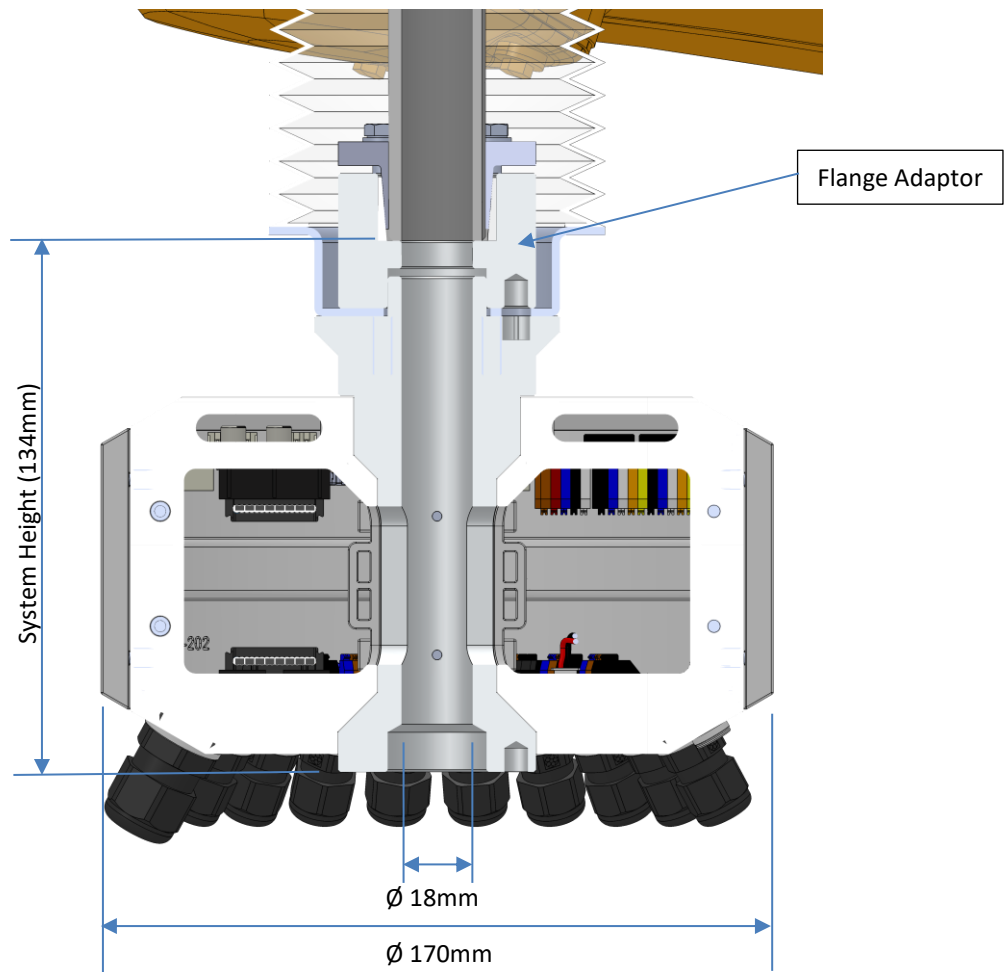
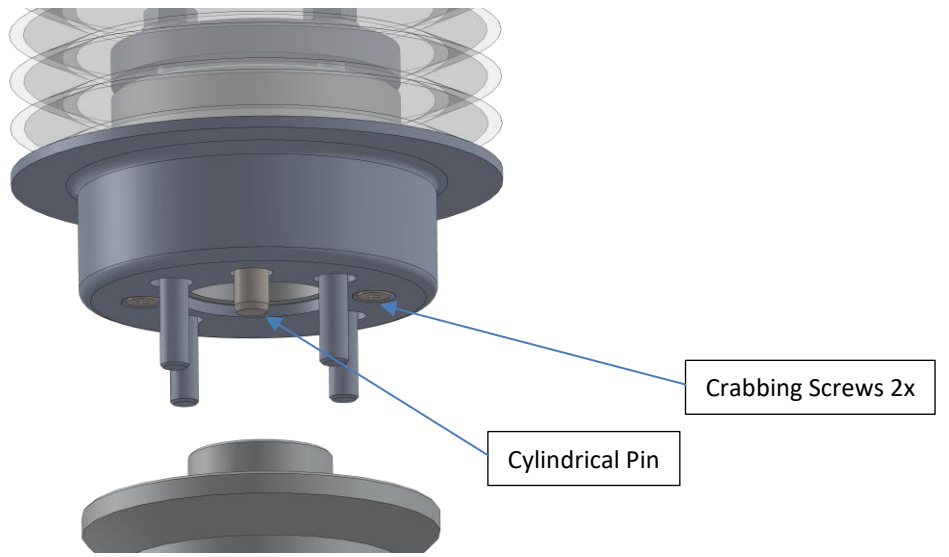

6.2.1. Installation

Make sure the ballscrew is extended so far, that enough workspace is located between the robot's case and the *ToolConnector* and that the position of the guide notch at 0 degrees is well known. There are 3 guide notches with 120° between each other. The notch at 0° can be identified clearly by the display on the manual control panel only.

Install the flange adaptor in the bellows with the aid of the two crabbing screws firstly. Pull the collet out of the socket until the ballscrew is easy to insert. Now push the ballscrew into the guidance until the limit stop.

Install now the *ToolConnector*. Position the *ToolConnector* on the basis of the pinhole at the lower flange and the guide notch at 0°. System related there is no guide pin in the ballscrew mounting part in the bellow version. Tighten the 4 tensioning screws uniformly in several runs (tightening moment 5 NM). Precede diagonal here. The use of a screw locking (e.g. LOCTITE 222) is highly recommended.

Finally, the upper end of the bellows can be attached to the robot.

6.2.2. Removing

Make sure the ballscrew is extended so far, that enough workspace is located between the robot's case and the *ToolConnector*. Detach the upper end of the bellows from the robot. Disconnect all connections that are running up the ballscrew. **Secure the *ToolConnector* from falling down.** Loosen the 4 tensioning screws completely. Now you can detach the *ToolConnector* from the flange adaptor. To remove the bellows, screw the two M5 x 15 (or longer) screws into the both assistance-threads until they have a freewheeling touch to the limit stop. Turn each of these two screws alternately forward until the flange adaptor can be detached easily from the ballscrew.

6.3. User-sided Assembling

6.3.1. Flange ISO 9409-1-40-4-M6

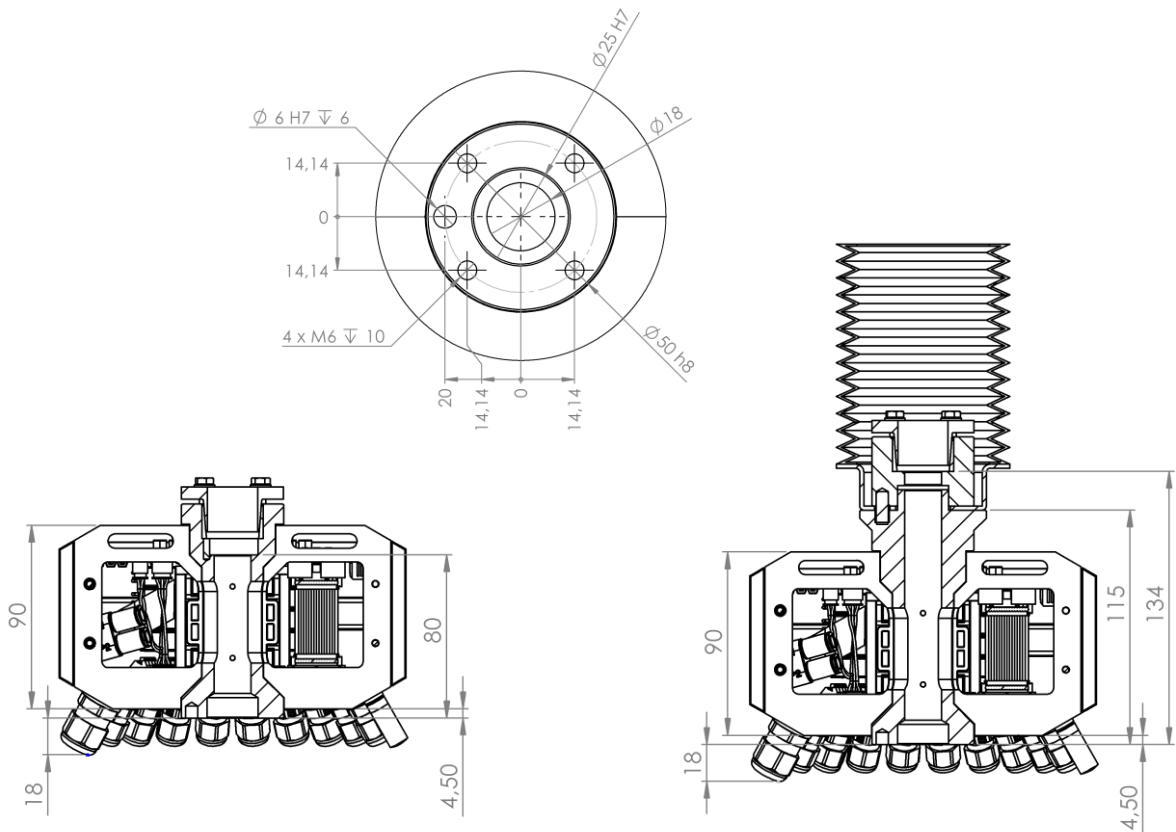

6.4. Case Options

6.4.1. Case with Screw Joints

The case option with screw joints comes with 18 synthetic screw joints M12 (\varnothing max 7mm) plus 2 synthetic screw joints M16 (\varnothing max 10mm).

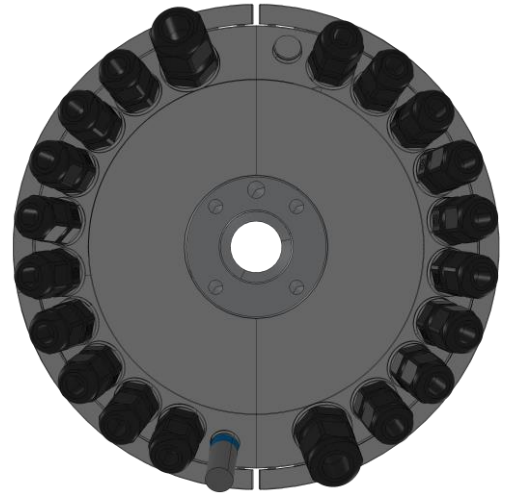

6.4.2. Case with Grommets

The case option with grommets comes with 18 grommets \varnothing max 6mm plus 2 grommets \varnothing max 9mm.

6.4.3. ESD Option

In the ESD option the case body is coated with conductive paint and it is connected conductive to the ballscrew. The leakage resistance represents $<3,5 \times 10^7 \Omega$ and equates the IEC 61340-5-1. The color is similar to RAL7035 light-grey.

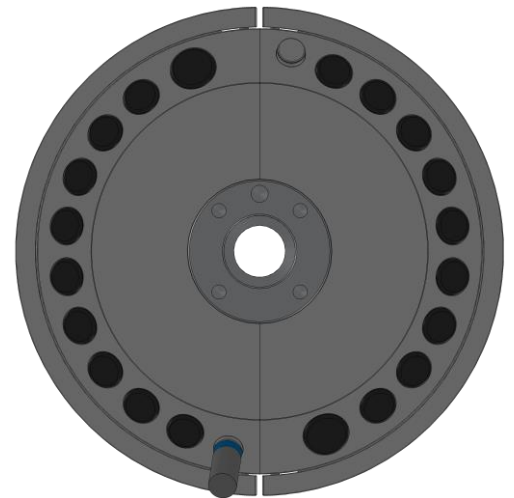

6.4.4. FDA Option

In the FDA option the case is built of a food conformable polyamide with a planed surface. Through this the adhesion of impurity is reduced.

7. Electrical System

7.1. Power-Supply Unit (19-1011-100-01)

Assembly area upper side B

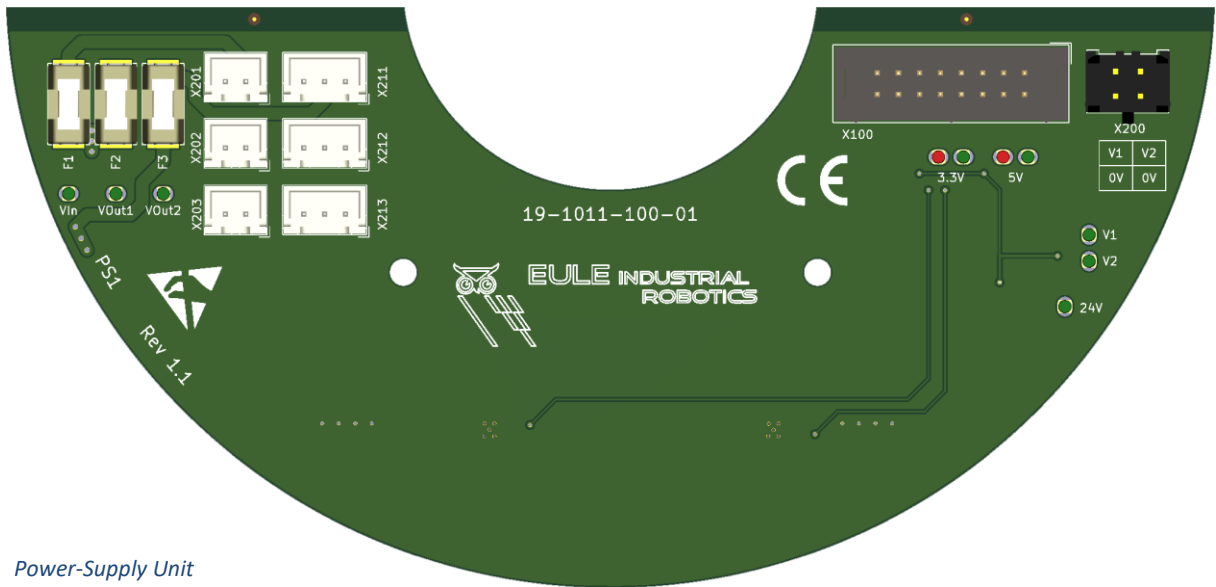

Power-Supply Unit

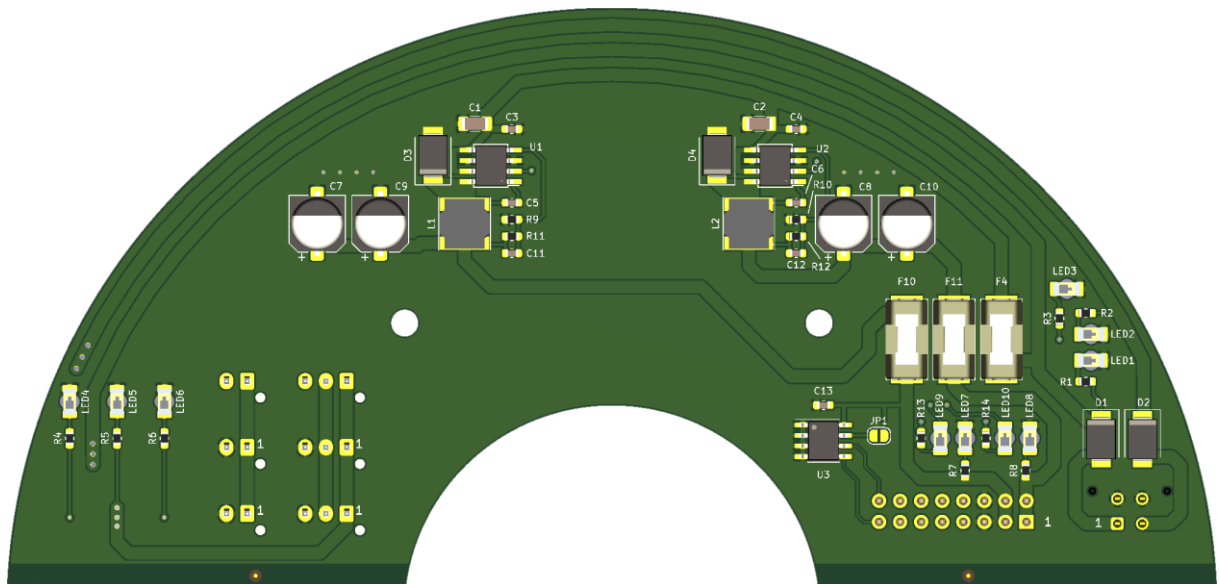

Power-Supply Unit Backside

7.1.1. Block Diagram

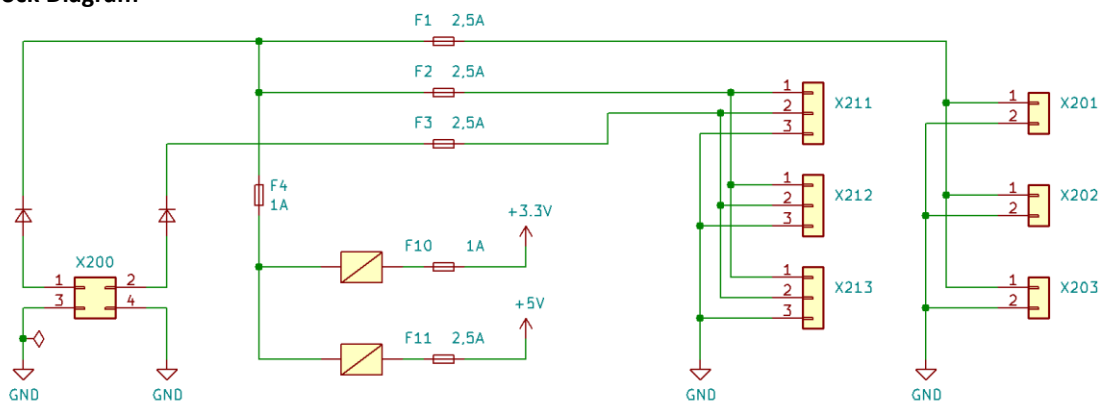

7.1.2. Voltage Supply (X200)

The voltage is provided to the device by the X200 plug-in connector.

Manufacturer: **Molex** Type: **43025-0400** + Crimp Contacts: **46235-0001**

Two 24V potentials can be supplied.

V1: Continuous voltage to provide current to the intern logic, the inputs and a part of the outputs.

V2: Potential on demand (emergency stop) to supply a part of the outputs.

0V: Ground. Both contacts are connected with each other internal.

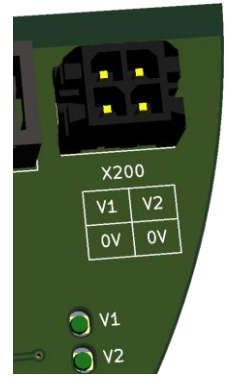

7.1.3. Fuses

All fuses of the device are based on the power-supply board and possible to exchange. There are miniature fuses in a 6,1 x 2,6 x 2,6mm³ format (6125) in use.

e.g.: Manufacturer: **Littlefuse** Production Run: **451, 452, 453, 454**
 Manufacturer: **SIBA** Production Run: **157000, 158000**

Fuse	Function	Position	Value
F1	V1 Inputs (X201, X202, X203)	Topside	2.5A
F2	V1 Outputs (X211, X212, X213)	Topside	2.5A
F3	V2 Outputs (X211, X212, X213)	Topside	2.5A
F4	24V intern	Backside	2.5A
F10	3.3V intern	Backside	1AF
F11	5V intern	Backside	2.5A

7.1.4. Diagnostic Indicator Lights (LED)

The following diagnostic LEDs are available:

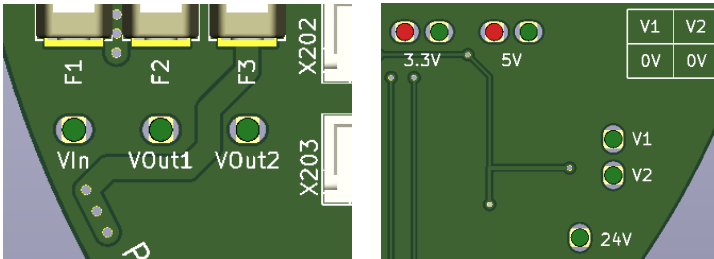

LED	Function	Fuse
V1	Voltage Supply V1 an X200 exist	-
V2	Voltage Supply V2 an X200 exist	-
VIn	VIn 24V for Inputs from V1 (X201, X202, X203)	F1
VOut1	VOut1 24V for Outputs from V1 (X211, X212, X213)	F2
VOut2	VOut2 24V for Outputs from V2 (X211, X212, X213)	F3
24V	24V internal exist (from V1)	F4
3.3V green	3.3V internal exist	F10
3.3V red	3.3V internal failure	-
5V green	5V internal exist	F11
5V red	5V internal exist	-

7.1.5. Supply Plug (X20x, X21x)

These plug-in connectors are used for the 24V voltage supply to the separate boards.

Manufacturer: **JST** Types: **XHP-2** (X20x) und **XHP-3** (X21x)+ crimp contacts **BXH-001T-P0.6**

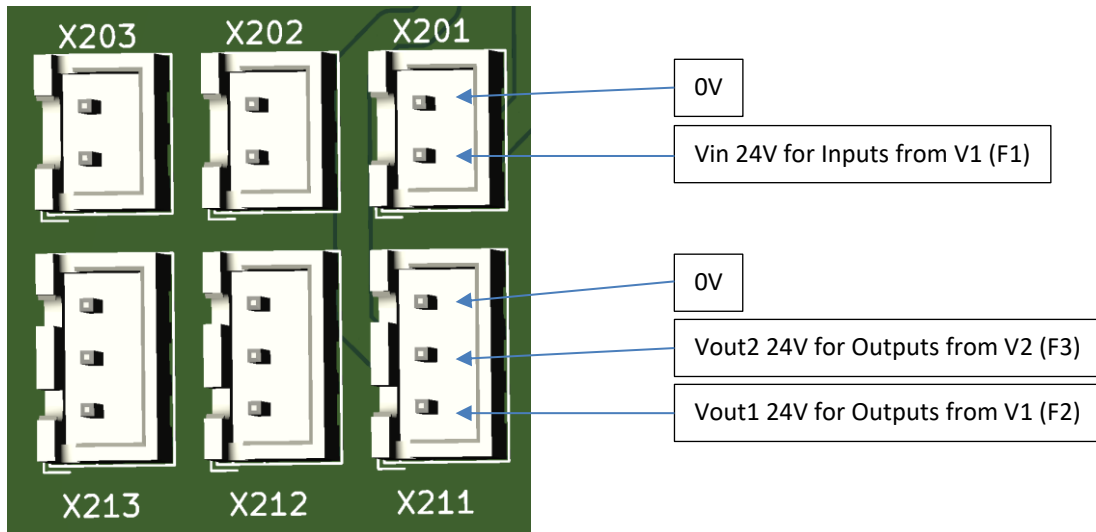

The three plug-in connectors of a group are having equal rights and are exchangeable between each other. It is necessary to consider the total current capacity of each circuit when external components are connected.

Plug-In	Primary Function
X201	Voltage Supply Inputs
X202	---
X203	---
X211	Voltage Supply IO-Link Master
X212	Voltage Supply Outputs
X213	---

7.1.6. Device-Bus (X100)

The individual circuit boards are connected across this plug-in connector by a ribbon cable.

7.2. Mainboard EtherCAT (19-1011-101-01 Ver. 1.2)

Assembly area upper side A

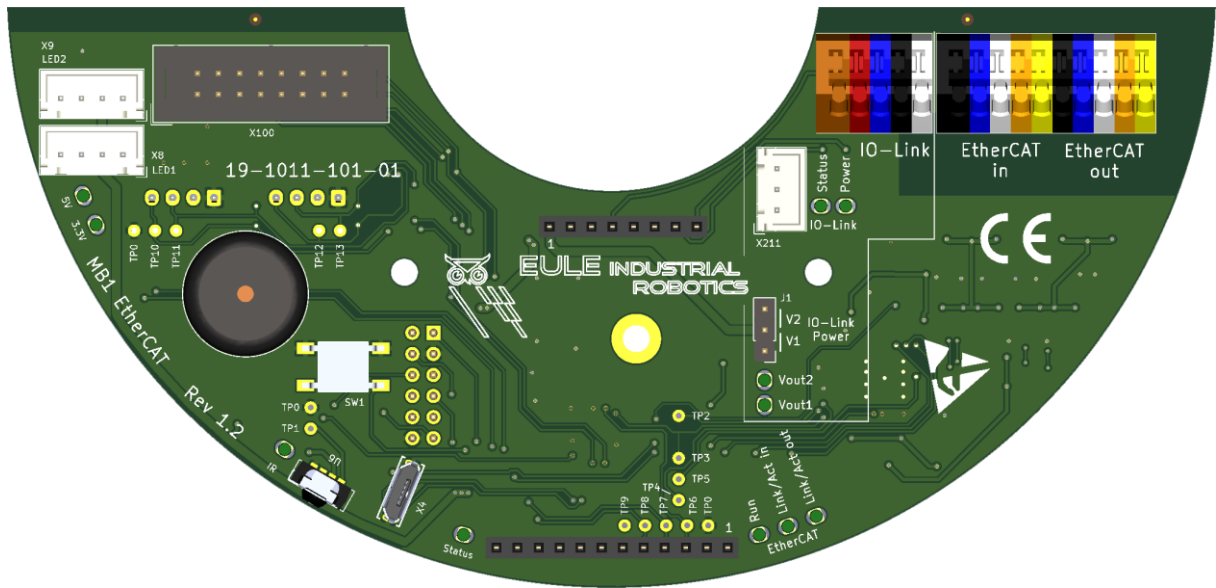

Mainboard EtherCAT

7.2.1. Device-Bus (X100)

The individual circuit boards are connected across this plug-in connector by a ribbon cable.

7.2.2. EtherCAT in/out

The EtherCAT field bus is connected across these spring-type terminals. The Terminals are reserved like in the following:



EtherCAT
To further Slaves

EtherCAT
from Controller

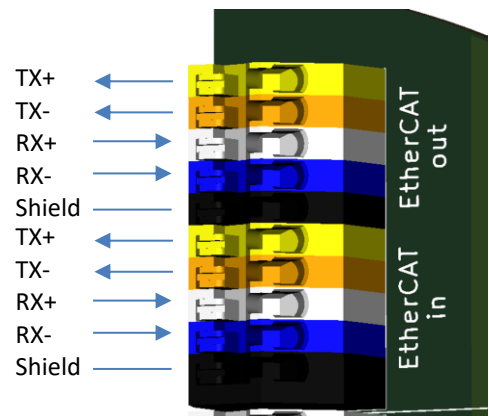

7.2.3. IO-Link

Currently not in use

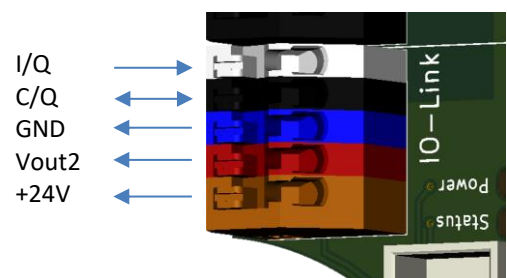

7.2.4. Voltage Supply IO-Link (X211)

Voltage supply for the IO-Link Master. Across a 3-pin connecting cable to the power supply unit (X221).

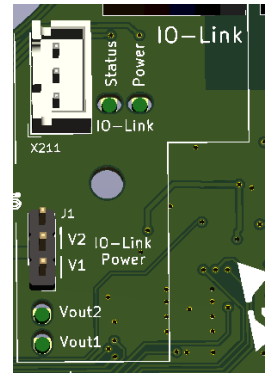

7.2.5. Voltage Selection IO-Link (J1)

The supply voltage for the IO-Link Master is selected between Vout1 and Vout2 by this jumper.

7.2.6. LED-Bus (X8, X9)

The case-LEDs are connected to these to plug-in connectors.

X8 LEDs 1-12 (Side A Inputs)

X9 LEDs 13-24 (Side B Outputs)

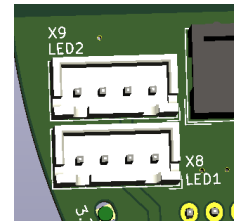

7.2.7. Service-Port (X4)

Currently not in use

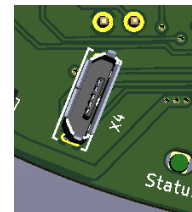

7.2.8. IR-Interface (IR)

Infrared interface for remote control functions.

See also 'User Manual Part II Software'.

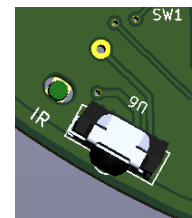

7.2.9. Pushbutton (SW1)

For function see 'Part II Software' chapter 'installation'

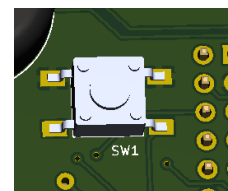

7.2.10. Diagnostic Indicator Lights (LED)

The following diagnostic LEDs are available:

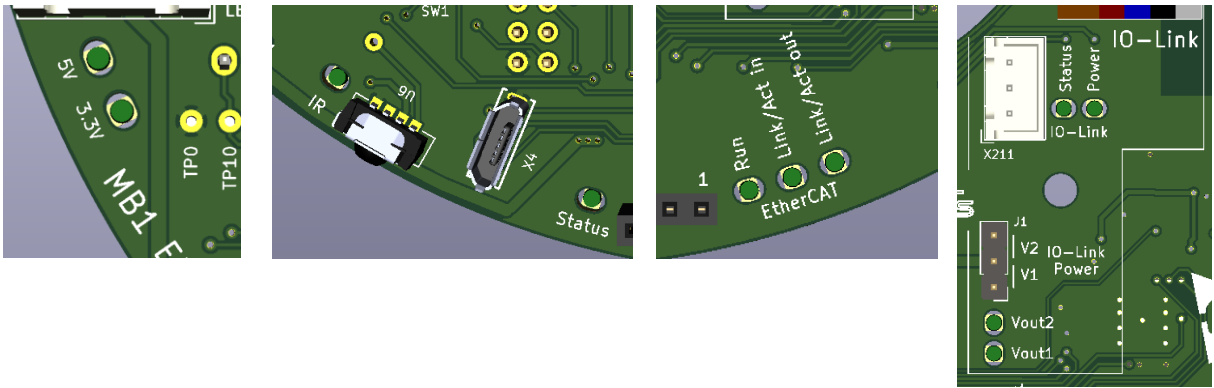

LED	Function
3.3V	3.3V internal exist
5V	5V internal exist
IR	Activity display and standby of the IR-interface
Status	Status display Mainboard
EtherCAT Run	Status EtherCAT activation
EtherCAT Terminal/Act In	Activity display EtherCAT In
EtherCAT Terminal/Act Out	Activity display EtherCAT Out
IO-Link Status	Status display IOLink Master (currently not in use)
IO-Link Power	IO-Link output voltage active
Vout1	Voltage Vout1 exist (von X211) for IO-Terminal
Vout2	Voltage Vout2 exist (von X211) for IO-Terminal

7.2.11. Remote Control

The individual functions of the *ToolConnector* can be operated by the remote control. This is especially useful for maintenance and installation of the device. It is an infrared remote control with no correlation to one special *ToolConnector*. Therefore, every remote control can be used for all devices. The range is limited to avoid misuses of other devices that are located around. The receiver is placed on the mainboard. The remote control also works with the case closed because of the IR-penetrable front foil.

Spare Battery: CR2025 for RC1 2x AAA for RC2

Details of the function are seen in the user manual part II.

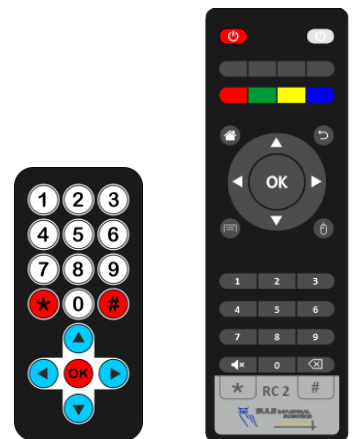

RC 1 (until 12/2022) RC 2 (from 01/2023)

7.3. Digital Inputs DI16 (19-1011-102-01 Ver. 1.1)

Assembly area lower side A

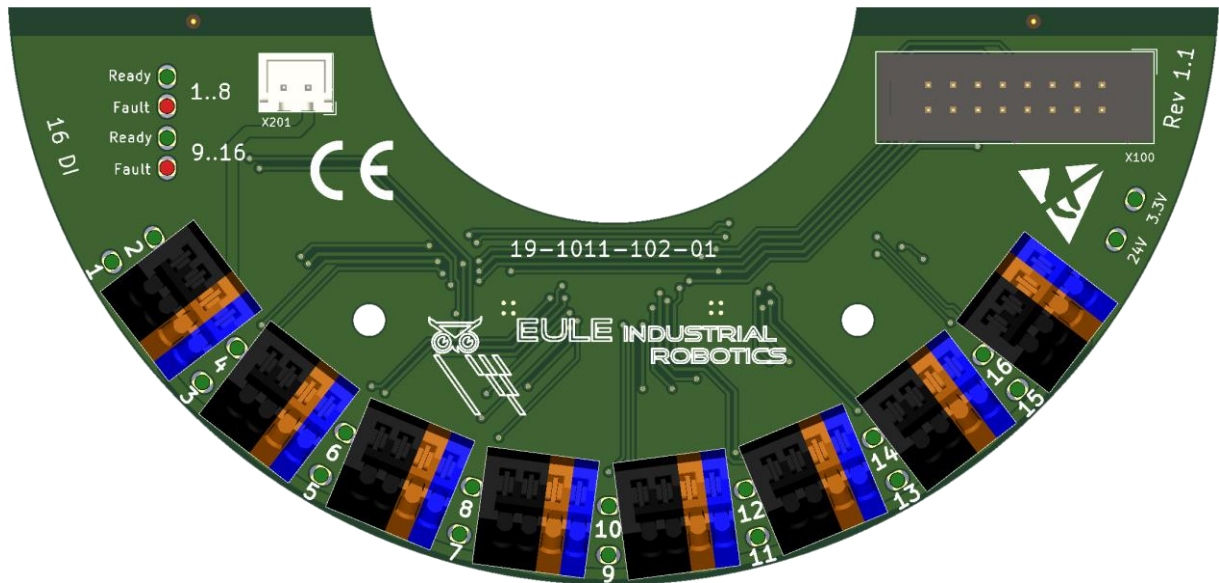

DI16

7.3.1. Technical Data

16 digital inputs according to IEC 61131-2

Voltage Supply to the Sensors	:	0V / 24V
Maximum Supply Current (summation)	:	1A
Input Voltage 0	:	0...5V
Input Voltage 1	:	12...30V
Input Current at 24V	:	max. 2.5mA
Maximum Terminal Cross-Section	:	0,5mm ²

7.3.2. Block Diagram

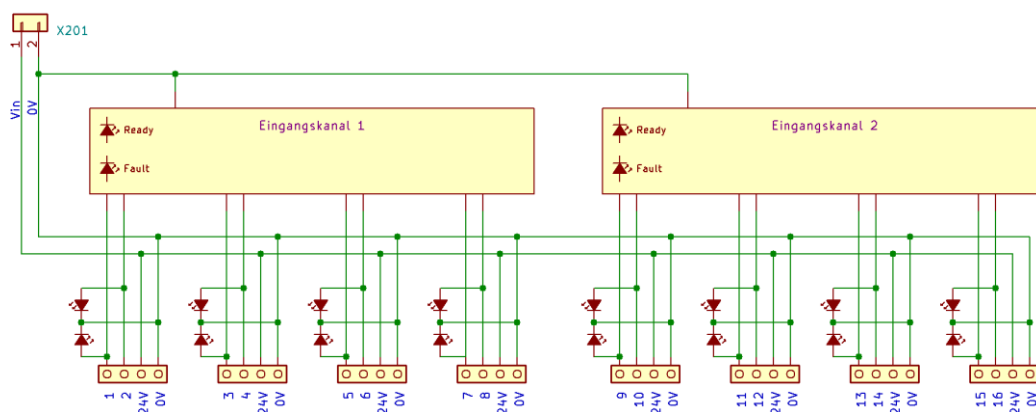

7.3.3. Device-Bus (X100)

The individual circuit boards are connected across this plug-in connector by a ribbon cable.

7.3.1. Voltage Supply (X201)

Voltage supply of the inputs. Via 2-pin connection wire to the power-supply unit (X201).

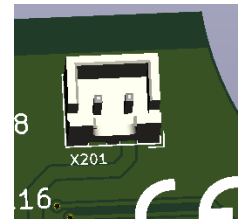

7.3.2. Input Terminal

The module has 8 spring-type terminals to connect sensors.

There are 2 input signals as well as a 0V and a 24V connection available per terminal.

The maximum connection cross-section represents 0,5mm².

The particular status of each input is displayed by a LED next to the terminal.

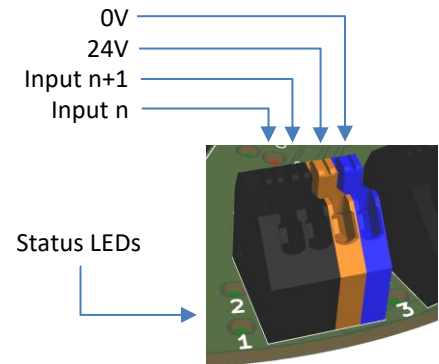

7.3.3. Diagnostic Indicator-Lights (LED)

The following diagnostic-LEDs are available:

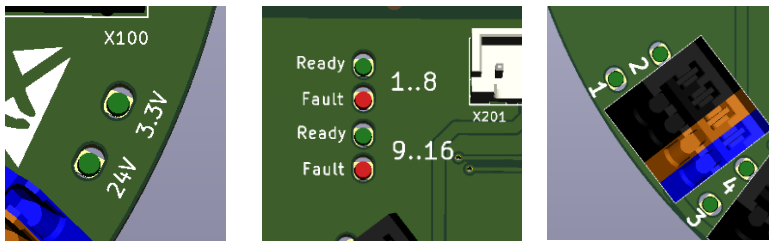

LED	Function
3.3V	3.3V internal exist
24V	24V Voltage Supply Sensors exist (from X201, F1)
Ready 1...8	Input Channel 1 Ready (Input 1...8)
Fault 1...8	Input Channel 1 Fault (Input 1...8)
Ready 9...16	Input Channel 2 Ready (Input 9...16)
Fault 9...16	Input Channel 2 Fault (Input 9...16)
1...16	Status Display of the Inputs 1...16

7.4. Digital Outputs DO16 (19-1011-103-01 Ver. 1.1)

Assembly area lower side B

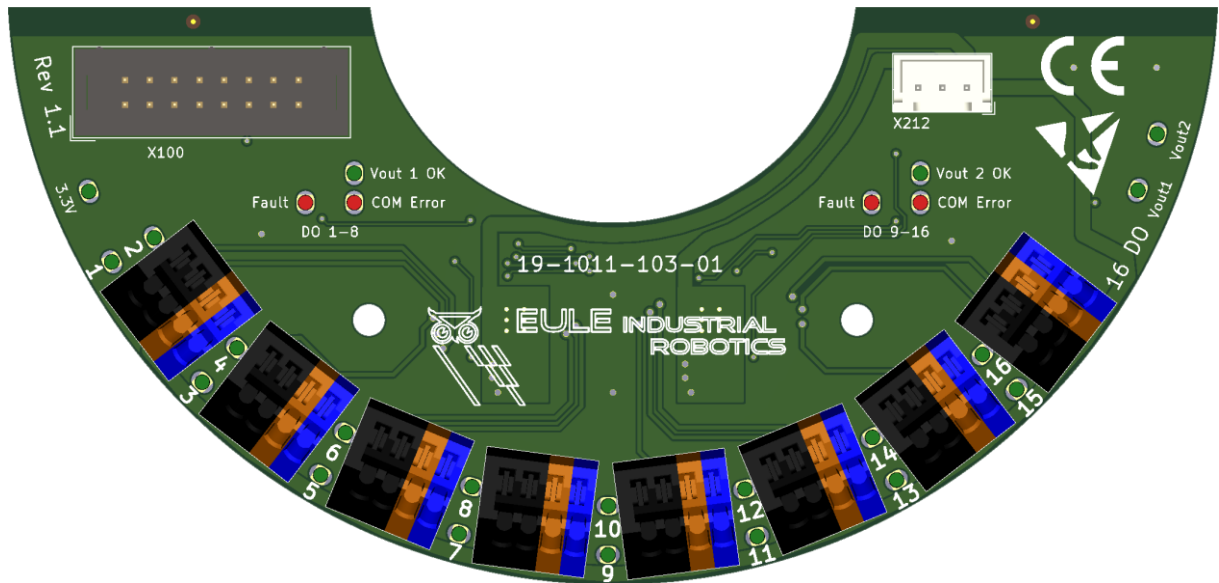

DO16

7.4.1. Technical Data

16 digital outputs according to IEC 61131-2

Voltage Supply to the Actuators	:	0V / 24V
Maximum Output Current (channel)	:	0.5A
Maximum Output Current (summation)	:	2A
Output Voltage	:	24V
Maximum connection Cross-Section	:	0,5mm ²

7.4.1. Block Diagram

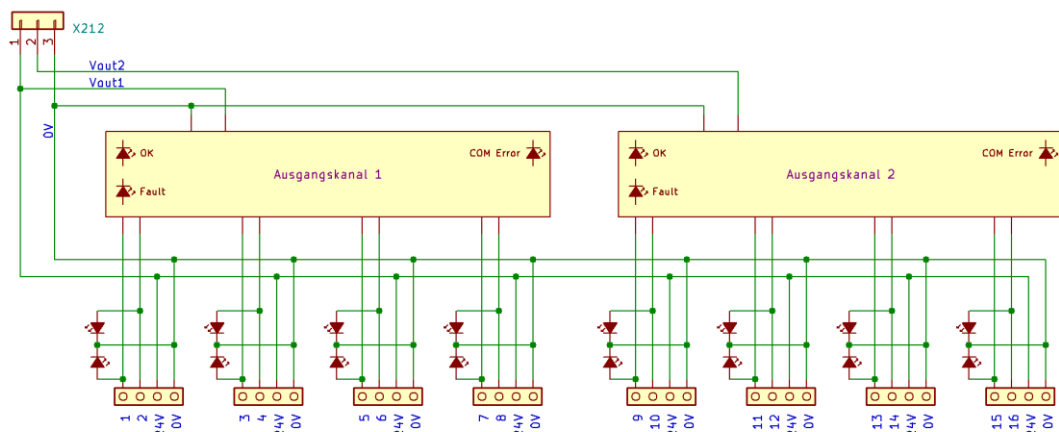

7.4.2. Device-Bus (X100)

The individual circuit boards are connected across this plug-in connector by a ribbon cable.

7.4.3. Voltage Supply (X212)

Voltage supply of the outputs. Via 3-pin connection wire to the power-supply unit (X212).

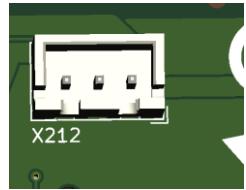

7.4.4. Output Terminal

The module has 8 spring-type terminals to connect sensors.

There are 2 output signals as well as a 0V and a 24V connection available per terminal. The 24V jumpers are connected to the potential Vout1. The potential Vout1 is operated by the outputs 1...8, the potential Vout2 by the outputs 9...16.

The maximum connection cross-section represents 0,5mm².

The particular status of each output is displayed by a LED next to the terminal.

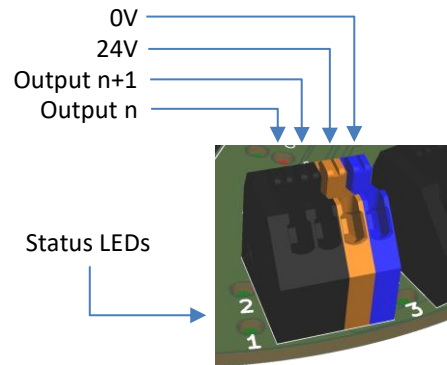

7.4.5. Diagnostic Indicator Lights (LED)

The following diagnostic-LEDs are available:

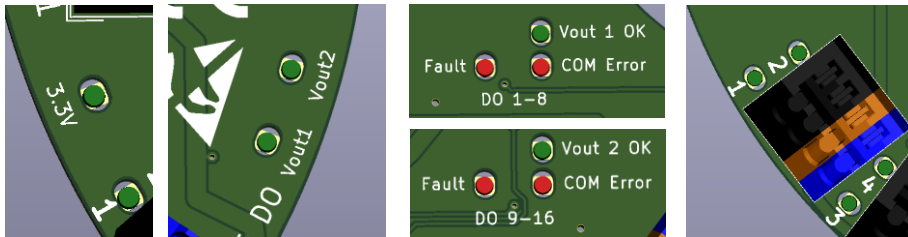

LED	Function
3.3V	3.3V internal exist
Vout1	24V Voltage Supply Vout1 exist (from X212, F2)
Vout2	24V Voltage Supply Vout2 exist (from X212, F3)
Vout 1 OK	Output Channel 1 Ready (Output 1...8)
Fault DO 1-8	Output Channel 1 Fault (Output 1...8)
COM Error DO 1-8	Output Channel 1 Bus Error (Output 1...8)
Vout 2 OK	Output Channel 2 Ready (Output 9...16)
Fault DO 9-16	Output Channel 2 Fault (Output 9...16)
COM Error DO 9-16	Output Channel 2 Bus Error (Output 9...16)
1...16	Status Display of the Outputs 1...16

7.5. Case LEDs

The case covers are optionally equipped with RGB-LEDs which can be triggered by the fieldbus independently of each other. 12 LEDs are located in each cover.

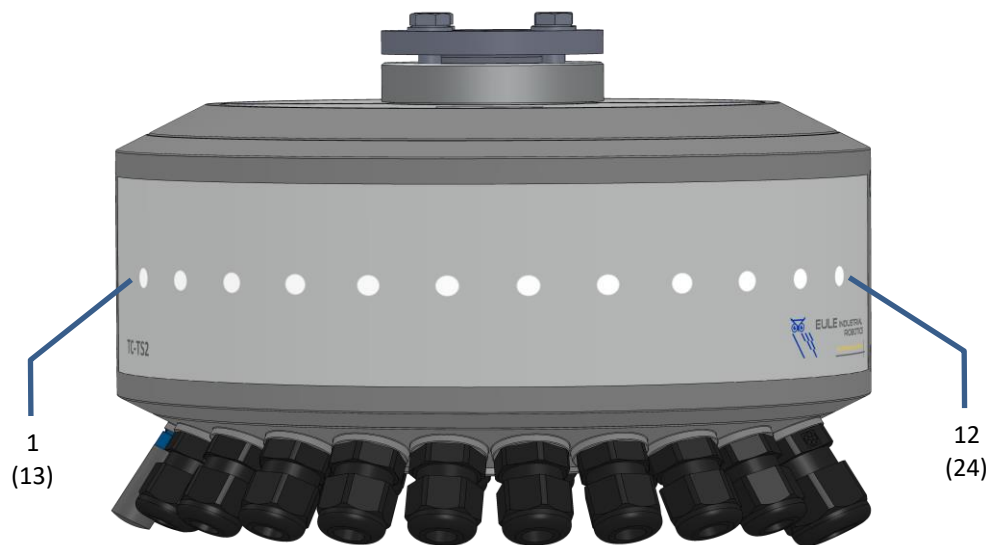

The LEDs 1...12 are located on the input sided (A) cover, the LEDs 13...24 on the output sided (B) cover.

The LEDs are linked to the mainboard via plug-in connector (s. chapter 7.2.6).

8. Pneumatic System

There is the possibility to install up to four (seven) valves in the *ToolConnector*. The installation occurs on the case side B above the output board. A second valve block can be installed on case side A optionally. There can be mounted 3 other valves. Therefore, the uppermost valve spot (V5) is not possible to be used.

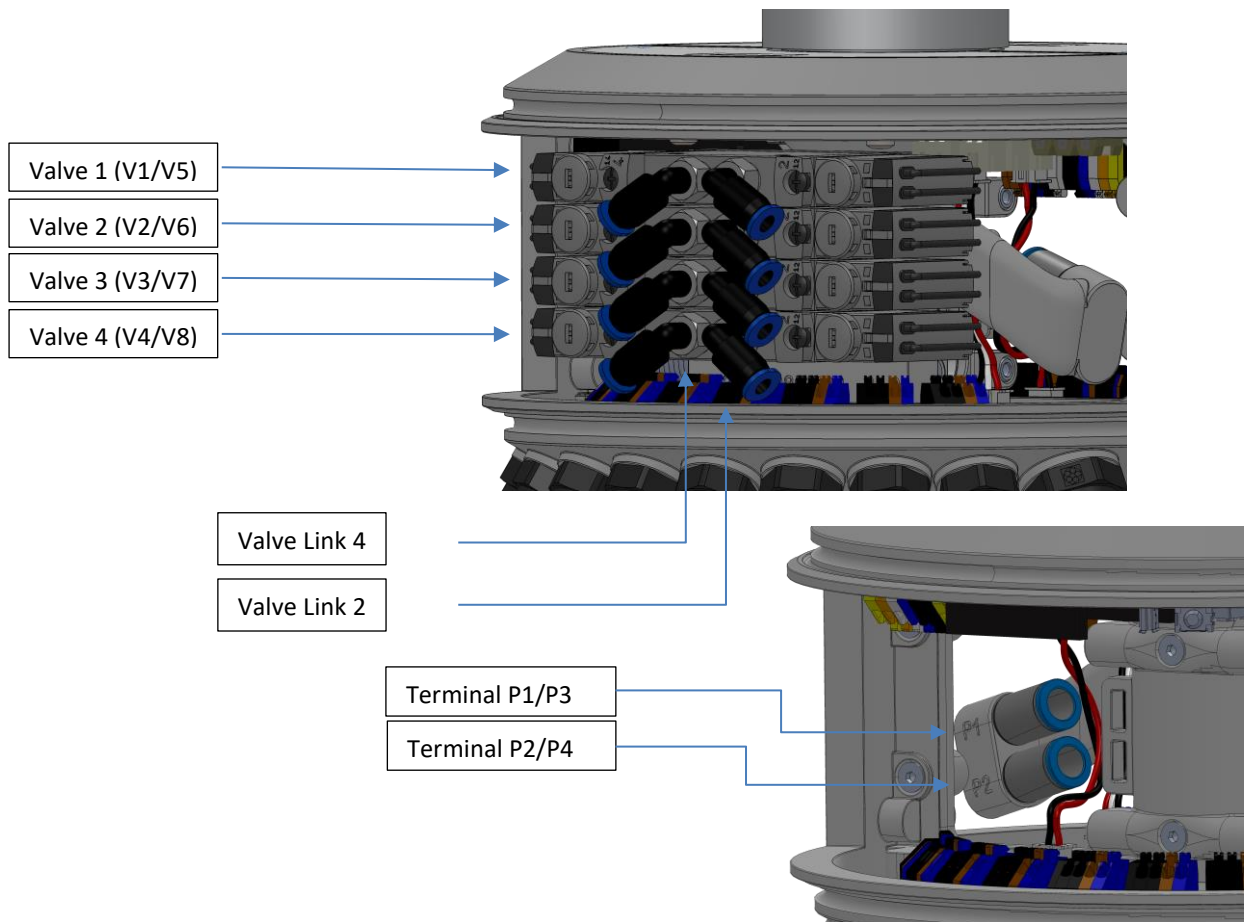

The air supply occurs via hoses through the ballscrew and the connections P1 and P2. M7 quick connectors for hoses with 4mm or 6mm outside diameter are available optionally.

The notation of the connections at the 2nd valve block is P3 and P4. P3 is not usable in the 1/3 option as the first valve spot (V5) is not usable.

The connections 2 and 4 of the valves are equipped with M5 angled screw couplings for 4mm hoses.

Maximum operation pressure: 6 Bar !



8.1. Valve Blocks

8.1.1. Types of Valve Blocks

Two different types of valve blocks are available. The valve blocks differ in distribution of the incoming air.

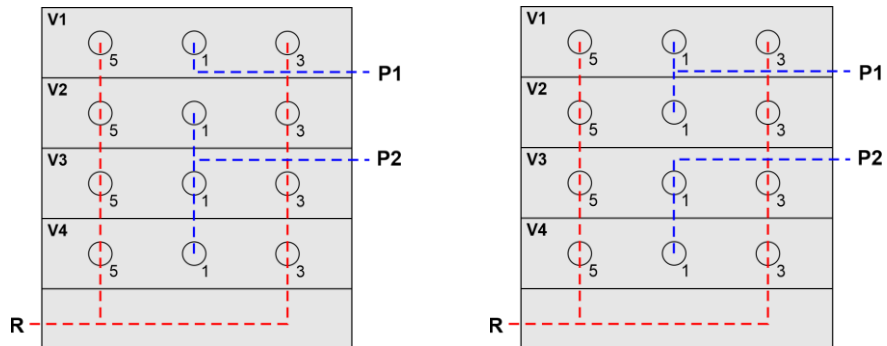

The accumulated outlet air is channeled out of the device via a silencer.

8.1.2. Valve Block Installation/Removing

Attention !!!

The operating pressure must be deactivated and the system must be evacuated before removing.



All valves and the bus cable must be dismantled before removing the valve block.

Bus Cable

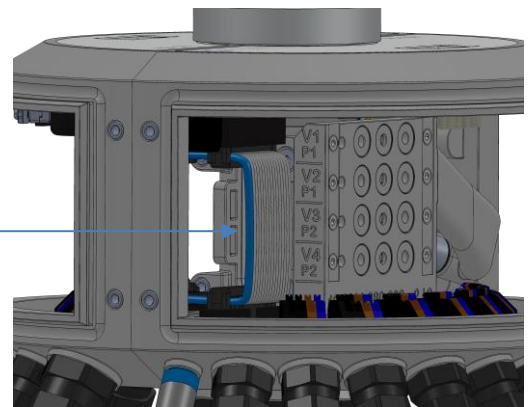

Afterwards, the four fixing screws must be released.

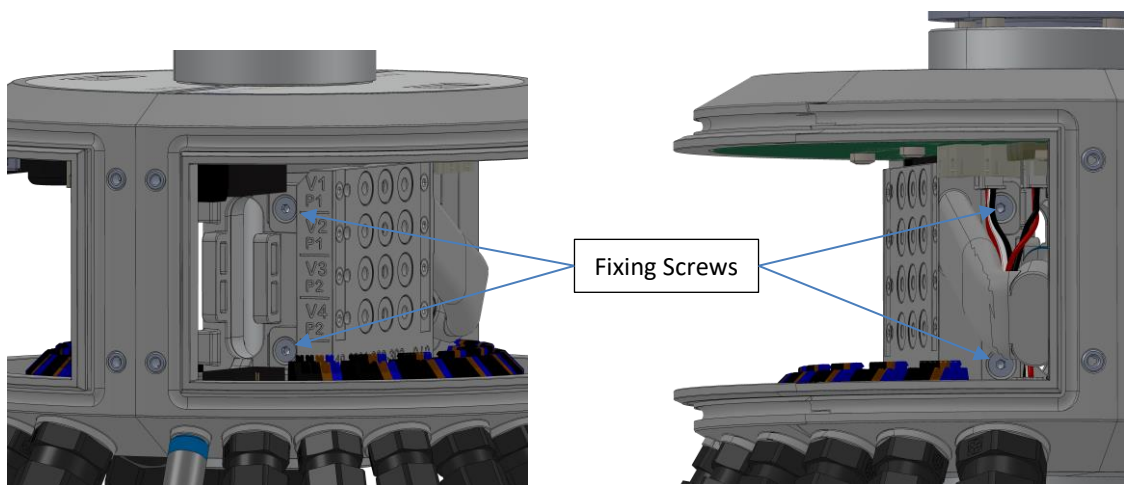

Now the valve block can be pulled out to the front.

When installing the valve block, proceed in inverse order. The correct fit of the sealing ring must be ensured. A non-hardening surface sealant can be added to the exhaust air socket of the valve block additionally when inserting it into the outlet air channel (e.g. HYLOMAR).

Outlet Air Channel

Joint Ring

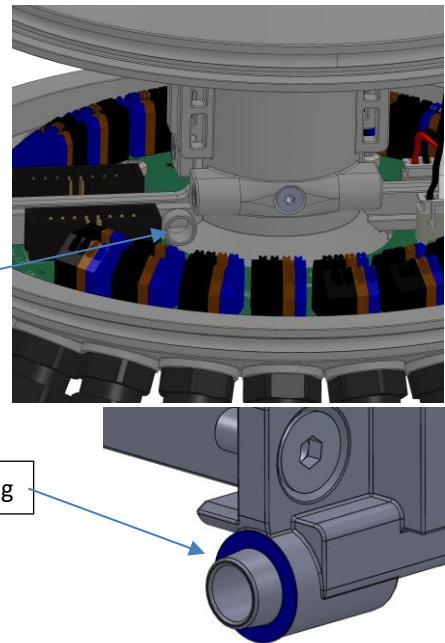

8.2. Valves

8.2.1. Types of Valves

The following valve-types are available.

A	5/2-way-valve, monostable	
B	5/2-way-valve, bistable	
C	5/3-way-valve, center position closed	
D	5/3-way-valve, center position vented	
E	5/3-way-valve, center position ventilated	
F	2x 3/2-way-valve, rest position closed	
G	2x 3/2-way-valve, rest position open	
H	2x 3/2-way-valve, rest position open/closed	
X	Dummy Board	

Valve spots that are not in must can be closed by dummy boards if necessary (X).

8.2.2. Valves Installation/Removing

Attention !!!

The operating pressure must be deactivated and the system must be evacuated before removing.



The two fixing screws of the valves must be released to remove the valves.

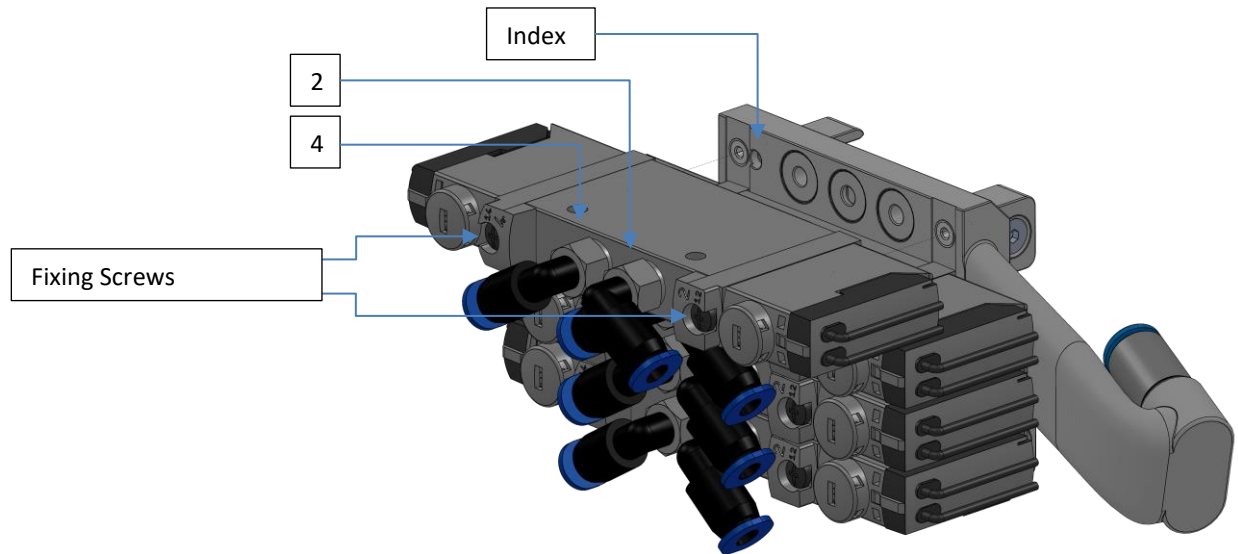

The correct mounting orientation and the correct position of the index hole must be ensured during the installation. Respect the correct fit of the sealing.

The electrical connection occurs at the spring-type terminals of the output module depending on the needs of the application.

9. Spare Parts

Pos.	Notation	Art. No. 19-2201-
1.1	Half-Case without Cover for Screw-Joints	080-101-SP
	Half-Case without Cover for Grommets	080-102-SP
	Half-Case without Cover ESD for Screw-Joints	080-101-ESD-SP
	Half-Case without Cover ESD for Grommets	080-102-ESD-SP
	Half-Case without Cover FDA for Screw-Joints	080-101-FDA-SP
1.2	Cover without LEDs	080-201-SP
	Cover with LEDs A (Inputs)	080-202-SP1
	Cover LEDs B (Outputs)	080-202-SP2
	Cover ESD without LEDs	080-201-ESD-SP
	Cover ESD with LEDs A (Inputs)	080-202-ESD-SP1
	Cover ESD with LEDs B (Outputs)	080-202-ESD-SP2
	Cover FDA without LEDs	080-203-FDA-SP
	Cover FDA with LEDs A (Inputs)	080-203-FDA-SP1
	Cover FDA with LEDs B (Outputs)	080-203-FDA-SP2
	Cover Seal	080-210-SP
1.3	Clamping Screws (Set)	901-001-SP
1.4	Flange BH 80 ISO 9409-1-40-4-M6	080-001-SP
1.5	Screw Joints (Set) 9xM12 1xM16	901-010-SP
1.6	Grommets (Set) 9x small 1x large	901-011-SP
2.1	Power-Supply Unit	100-01-SP
2.2	Mainboard EtherCAT	101-01-SP
2.3	Input Module DI16	102-01-SP
2.4	Output Module DO16	103-01-SP
2.5	Bus Cable	199-01-SP
2.6	Display	199-10-SP
--	Cable Voltage-Supply 2-pin (X20x)	199-02-SP
--	Cable Voltage-Supply 3-pin (X21x)	199-03-SP
--	Replacement-Fuse Set 5x 2,5A 1x 1A	199-20-SP
--	IR-Remote Control RC2	199-50-SP
--	Replacement-Battery for RC1 Remote Control (CR2025)	199-51-SP
3.1	Valve Block 1/3 (P1/P2/V1...V4)	080-301-SP
	Valve Block 2/2 (P1/P2/V1...V4)	080-302-SP
	Valve Block 1/3 (P3/P4/V5...V8)	080-311-SP
	Valve Block 2/2 (P3/P4/V5...V8)	080-312-SP
3.2	Joint Ring Outlet Air Channel	902-020-SP
3.3	Quick Connector M7 for Hose 4mm	902-001-SP
	Quick Connector M7 for Hose 6mm	902-002-SP
3.4	5/2-Way-Valve, monostable	902-10A-SP
	5/2-Way-Valve, bistable	902-10B-SP
	5/3- Way-Valve, center position closed	902-10C-SP
	5/3- Way-Valve, center position vented	902-10D-SP
	5/3- Way-Valve, center position ventilated	902-10E-SP
	2x 3/2- Way-Valve, rest position closed	902-10F-SP
	2x 3/2- Way-Valve, rest position open	902-10G-SP
	2x 3/2- Way-Valve, rest position open/closed	902-10H-SP
	Dummy Board	902-10X-SP
	Valve Seal	902-100-SP
3.5	Angled Screw Coupling M5 for Hose 4mm	902-003-SP
3.6	Silencer M7	902-010-SP

